

# Peerless

A CECO Environmental Brand

PRODUCT BULLETIN  
**SEPARATION  
& FILTRATION  
SOLUTIONS**

HORIZONTAL & VERTICAL CONFIGURATIONS

**Keep your facility running at its peak with the best separation and filtration solutions in the industry. With over 80 years of proven performance, Peerless has the experience and reliability you need.**

## VANE SEPARATORS

*Applications: oil mist removal, chemical process gas, gas metering, steam drying, LNG*

- Horizontal or vertical separator configuration
- Maintenance free
- 100% turndown and a  $\Delta P < 1.0$  psi
- Tremendously high gas throughput
- Optional liquid slugging capability

- A** Inlet of wet gas
- B** Multiple inlet device options for initial separation
- C** Vane pack intercepts liquid droplets
- D** Liquids captured are isolated and drained
- E** Outlet of clean gas

### PERFORMANCE GUARANTEE

- 100% removal of liquids  $> 8$  microns
- $< 0.10$  gallon of liquid carryover per MMSCF

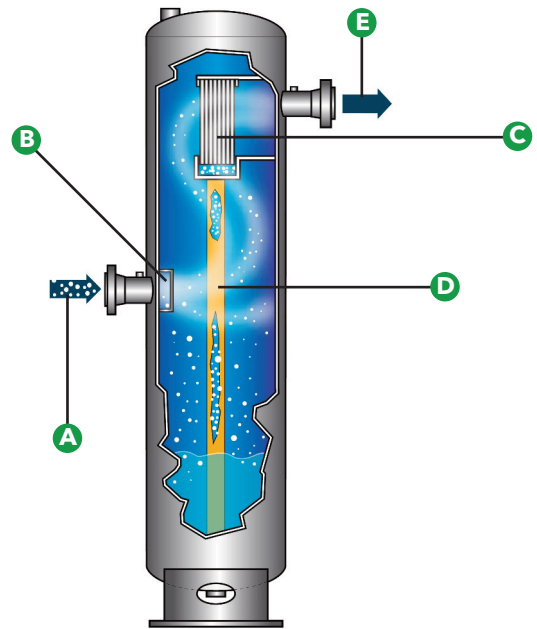

## CYCLONE SEPARATORS

*Applications: gas transmission, very dirty gas, bulk solids, biogas, landfill gas, geo-thermal, when filters are not practical*

- Horizontal or vertical separator configuration
- Maintenance free
- Constant  $\Delta P$  of 2.0-5.0 psi
- Robust self-cleaning design
- Optional liquid slugging capability

- A** Inlet of dirty gas
- B** Gas is spun to high speeds
- C** Contaminants drain out
- D** Outlet of clean gas

### PERFORMANCE GUARANTEE

- 100% removal of liquids and solids  $> 8$  microns
- 85%+ removal of solids 2 - 8 microns
- $< 0.10$  gallon of liquid carryover per MMSCF

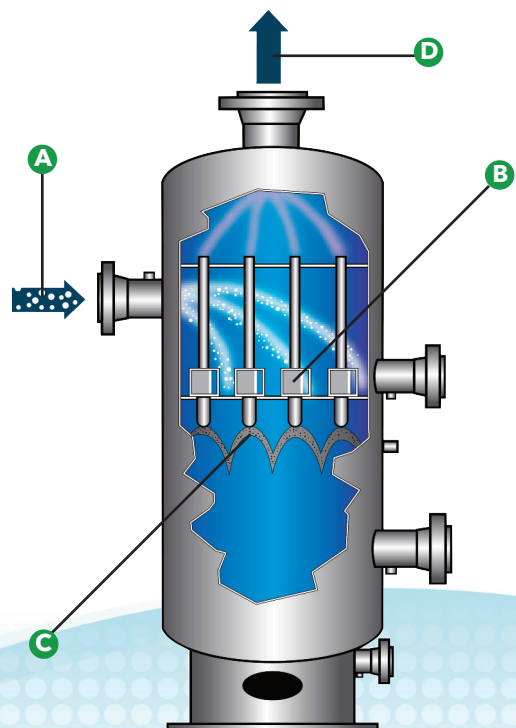

## ▶ SWIRL TUBE SEPARATORS

Applications: gas transmission, compressor inlets, steam drying

- Horizontal or vertical separator configuration
- Maintenance free
- Constant  $\Delta P$  of 2.0-5.0 psi
- Superior liquid removal efficiency
- Optional liquid slugging capability

- A** Inlet of wet gas
- B** Gas is spun to high speeds
- C** Contaminants drain out
- D** Outlet of clean gas

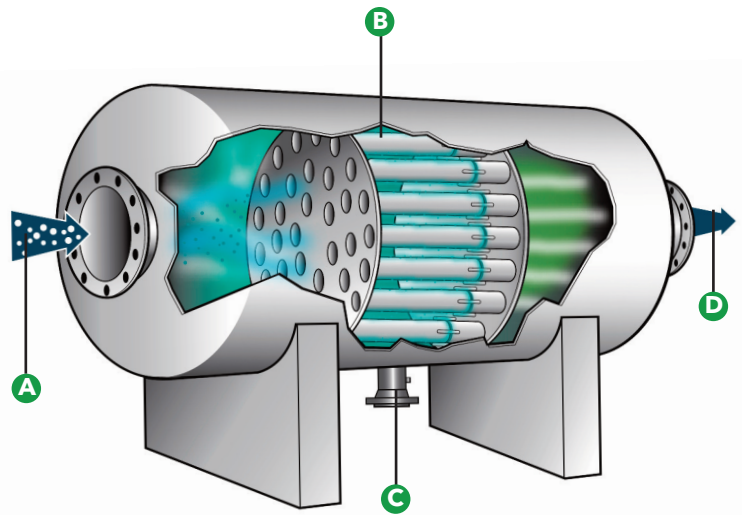

### PERFORMANCE GUARANTEE

- 100% removal of liquids > 6 microns
- 98%+ removal of liquids 2 - 6 microns
- < 0.10 gallon of carryover per MMSCF

## ▶ ULTRA & STANDARD FILTER SEPARATORS

Applications: gas transmission, compressor inlets, gas metering, LNG

- Horizontal or vertical separator configuration
- 100% turndown and a clean  $\Delta P$  < 2.0 psi
- Excellent removal of fine particles

- A** Inlet of dirty gas
- B** Superior, long-life coalescing filter elements
- C** QOC/flanged access to filter elements
- D** High speed P6X vane originally designed for NASA
- E** Outlet of clean gas

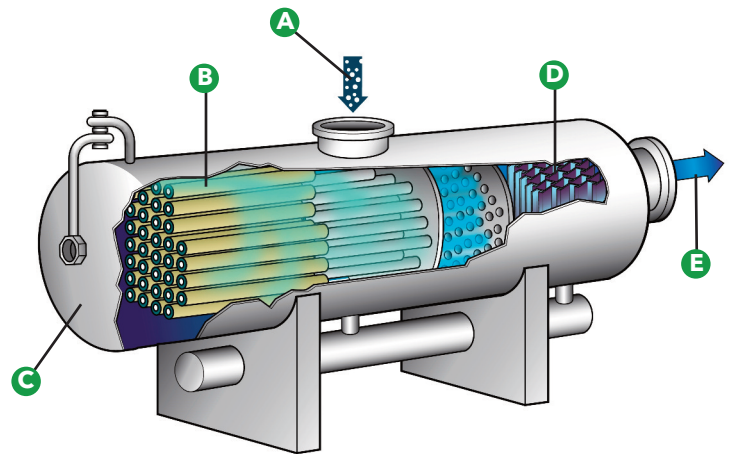

### PERFORMANCE GUARANTEE

- up to 99.99% removal of liquids > 0.5 microns
- up to 99.99% removal of solids > 0.3 microns

## ▶ ABSOLUTE FILTER SEPARATORS

Applications: critical gas processes, fuel gas, dryer bed inlets, mole sieve, amine contactor, catalyst protection, LNG

- Vertical separator configuration only
- 100% turndown and a clean  $\Delta P$  < 2.0 psi
- Optional liquid slugging capability

- A** Inlet of dirty gas
- B** Multiple inlet device options for initial separation
- C** Remarkably high-efficiency coalescing filter elements
- D** QOC/flanged access to filter elements
- E** Outlet of clean gas

### PERFORMANCE GUARANTEE

- up to 99.999% removal of liquids > 0.3 microns
- up to 99.999% removal of solids > 0.3 microns

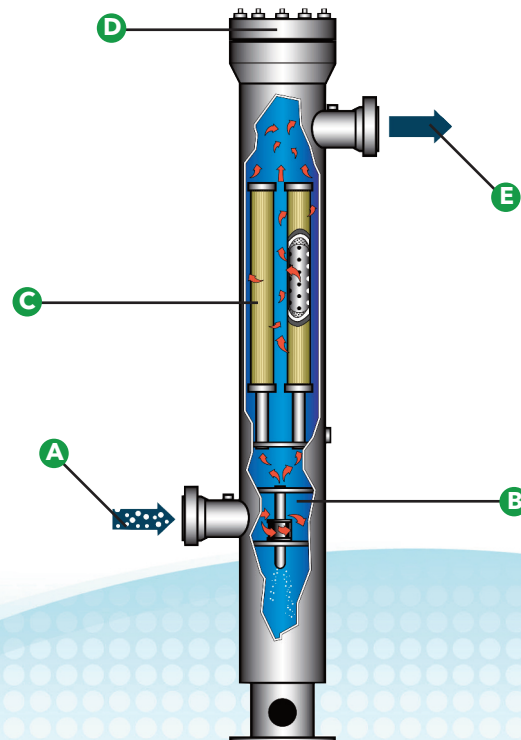

**Peerless**

A CECO Environmental Brand

14651 N. Dallas Parkway, Suite 500  
 Dallas, TX 75254 USA  
 +1 214.357.6181 • sales@peerlessmfg.com  
 peerlessmfg.com • cecoenviro.com